

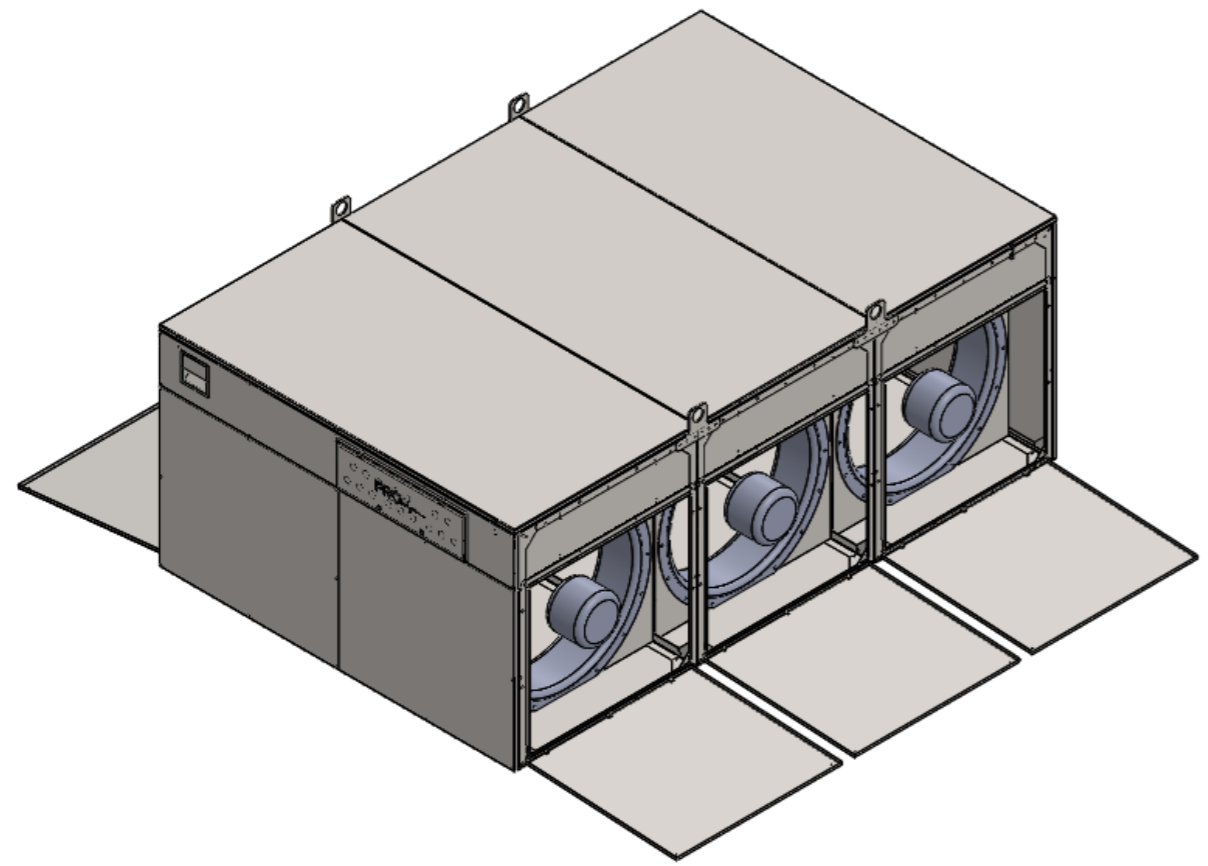

8 7 6 5 4 3 2 1

F  
E  
D  
C  
B  
A

F  
E  
D  
C  
B  
A

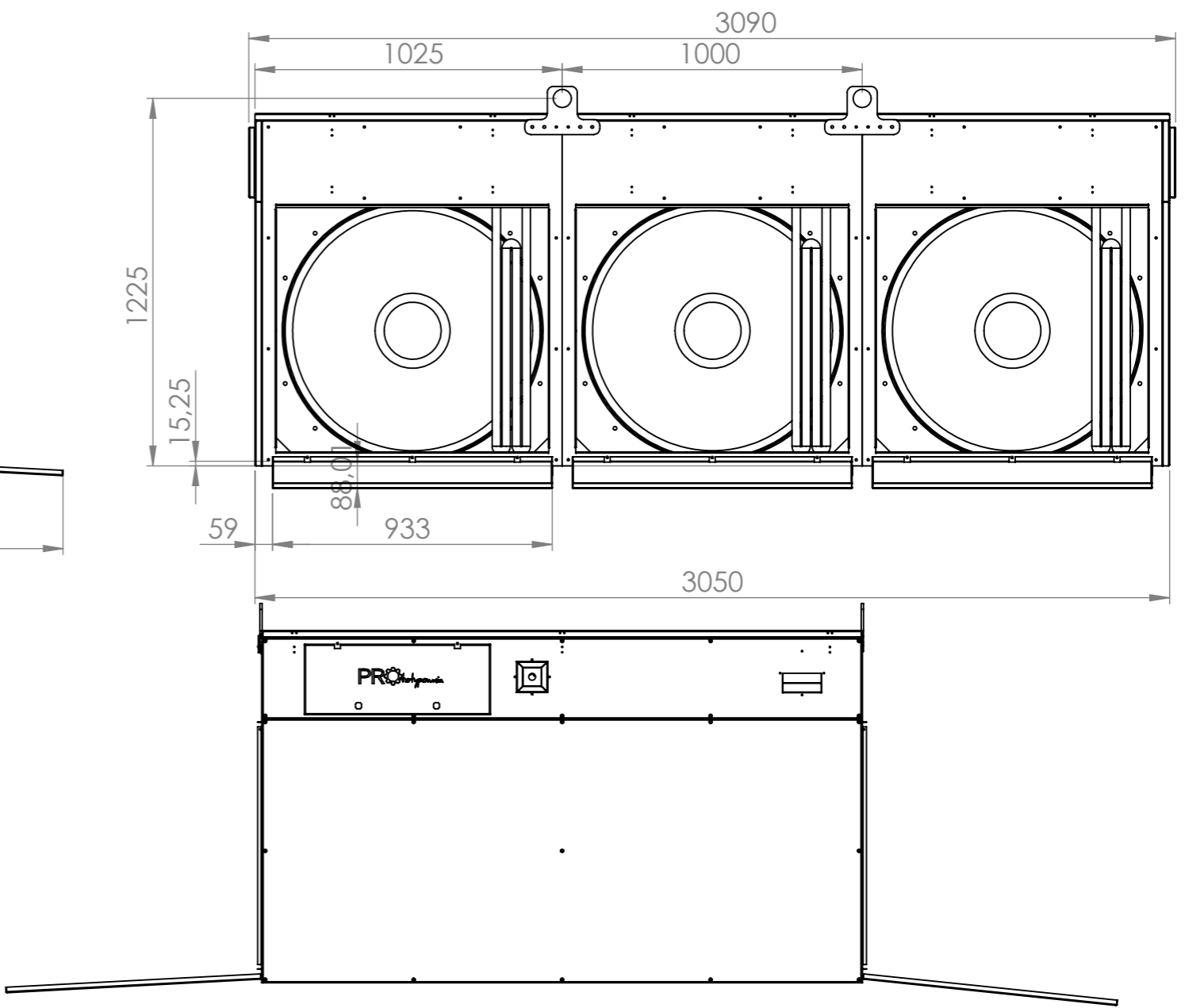
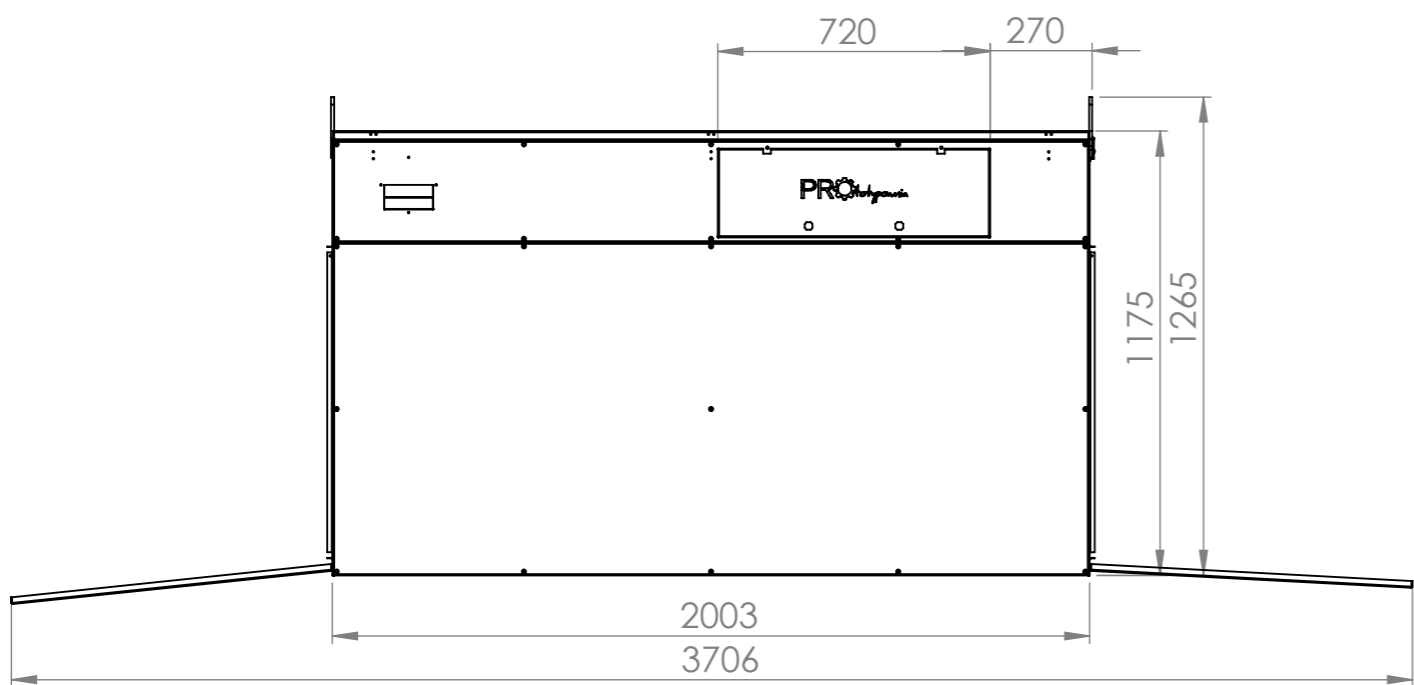

CHYBA ŻE OKREŚLONO INACZEJ: WYMIARY SĄ W MILIMETRACH WYKOŃCZENIE POWIERZCHNI: TOLERANCJE: LINIOWA: KĄTOWA:		WYKOŃCZENIE:		STEP OSTRE KRAWĘDZIE		NIE SKALUJ RYSUNKU		POPRAWKA	
						PROTOTYPOWNA ul. Kasztanowa 6A/1 lok.22 64-542 Młodasko			
						TYTUŁ: LB 1500			
						NR RYSUNKU			
						WAGA:			
						SKALA: 1:2			
						ARKUSZ 1 Z 1			
NARYS.		IMIE I NAZWISKO		PODPIS		DATA			
SPRAWDZ.									
ZATWIER.									
WYPROD.									
Z.JAKOŚCI								A3	

8 7 6 5 4 3 2 1